

Data sheet Zener barriers

| Type | | | Nominal data | | Intrinsically safe characteristics for [EEx ia] IIC | | | | | | | Certification no. |
|-----------|-----------|----------|--------------|-----|-----------------------------------------------------|----------------------|---------------------|----------------------|-----------------------|-----------------------|-----------|-------------------|
| + ve | - ve | a.c. | V | Ω | U _Z (V) | R _{min} (Ω) | I _K (mA) | P _{max} (W) | C _{max} (μF) | L _{max} (mH) | L/R Ratio | |
| Z 705 | Z 805 | - | 5 | 10 | 4.94 | 9.8 | 504 | 0.62 | 100 | 0.14 | 57 | BAS 01 ATEX 7005 |
| - | - | Z 905 | 5 | 10 | 4.98 | 9.8 | 499 | 0.61 | 100 | 0.14 | 57 | BAS 01 ATEX 7005 |
| Z 710 | Z 810 | - | 10 | 50 | 9.56 | 49 | 195 | 0.47 | 3 | 0.86 | 73 | BAS 01 ATEX 7005 |
| - | - | Z 910 | 10 | 50 | 9.94 | 49 | 203 | 0.50 | 3 | 0.86 | 73 | BAS 01 ATEX 7005 |
| Z 713 | Z 813 | - | 15.75 | 22 | 15.75 | 21.8 | 723 | 2.84 | 0.48 | 0.076 | 12.5 | BAS 01 ATEX 7005 |
| Z 715 | Z 815 | - | 15 | 100 | 14.7 | 98 | 150 | 0.55 | 0.58 | 1.3 | 64 | BAS 01 ATEX 7005 |
| Z 715.F | Z 815.F | - | 15 | 100 | 14.7 | 98 | 150 | 0.55 | 0.62 | 1.45 | 67 | BAS 01 ATEX 7096 |
| - | - | Z 915 | 15 | 100 | 15.0 | 98 | 153 | 0.57 | 0.58 | 1.3 | 64 | BAS 01 ATEX 7005 |
| Z 715.1K | - | - | 15 | 1k | 14.7 | 980 | 15 | 0.06 | 0.58 | 144 | 570 | BAS 01 ATEX 7005 |
| - | - | Z 915.1K | 15 | 1k | 15 | 980 | 15 | 0.06 | 0.58 | 144 | 570 | BAS 01 ATEX 7005 |
| Z 722 | Z 822 | - | 22 | 150 | 22 | 147 | 150 | 0.82 | 0.17 | 1.45 | 45 | BAS 01 ATEX 7005 |
| Z 728 | Z 828 | - | 28 | 300 | 28 | 301 | 93 | 0.65 | 0.083 | 3.05 | 56 | BAS 01 ATEX 7005 |
| Z 728.H | - | - | 28 | 240 | 28 | 235 | 119 | 0.83 | 0.083 | 1.82 | 44 | BAS 01 ATEX 7005 |
| Z 728.F | Z 828.F | - | 28 | 300 | 28 | 301 | 93 | 0.65 | 0.083 | 4.21 | 55 | BAS 01 ATEX 7096 |
| Z 728.H.F | Z 828.H.F | - | 28 | 240 | 28 | 235 | 119 | 0.83 | 0.083 | 2.59 | 44 | BAS 00 ATEX 7096 |
| Z 728.CL | Z 828.CL | - | 28 | 300 | 28 | 301 | 93 | 0.65 | 0.083 | 3.05 | 56 | BAS 01 ATEX 7005 |
| - | - | Z 928 | 28 | 300 | 28 | 301 | 93 | 0.65 | 0.083 | 3.05 | 56 | BAS 01 ATEX 7005 |
| Z 755 | - | - | 5 | 10 | 4.94 | 9.8 | 504 | 0.62 | 100 | 0.14 | 57 | BAS 01 ATEX 7005 |
| - | - | - | 5 | 10 | 4.94 | 9.8 | 504 | 0.62 | 100 | 0.14 | 57 | |
| - | - | - | 5 | 10 | 4.94 | 4.9 | 1008 | 1.25 | 100 | 0.03 | 22 | |
| - | - | Z 955 | 5 | 10 | 4.89 | 9.8 | 499 | 0.61 | 100 | 0.14 | 57 | BAS 01 ATEX 7005 |
| - | - | - | 5 | 10 | 4.89 | 9.8 | 499 | 0.61 | 100 | 0.14 | 57 | |
| - | - | - | 5 | 10 | 9.78 | 4.9 | 998 | 1.22 | 3.3 | 0.03 | 22 | |
| Z 757 | Z 857 | - | 7 | 10 | 7.14 | 9.8 | 729 | 1.3 | 13.5 | 0.07 | 28 | BAS 01 ATEX 7005 |
| - | - | - | 7 | 10 | 7.14 | 9.8 | 729 | 1.3 | 13.5 | 0.07 | 28 | |
| - | - | - | 7 | 10 | 7.14 | 4.9 | 1457 | 2.6 | 13.5 | 0.02 | 11 | |
| - | - | Z 961 | 9 | 100 | 8.7 | 98 | 89 | 0.19 | 4.9 | 4.69 | 182 | BAS 01 ATEX 7005 |
| - | - | - | 9 | 100 | 8.7 | 98 | 89 | 0.19 | 4.9 | 4.69 | 182 | |
| - | - | - | 9 | 100 | 17.4 | 98 | 178 | 0.39 | 0.346 | 1.14 | 72 | |
| - | - | Z 961.F | 9 | 100 | 8.7 | 98 | 89 | 0.192 | 4.9 | 4.39 | 176 | BAS 01 ATEX 7096 |
| - | - | - | 9 | 100 | 8.7 | 98 | 89 | 0.192 | 4.9 | 4.39 | 176 | |
| - | - | - | 9 | 100 | 17.4 | 98 | 178 | 0.384 | 0.31 | 1.07 | 67 | |
| - | - | Z 961.H | 9 | 360 | 8.7 | 352.8 | 25 | 0.05 | 4.9 | 57 | 613 | BAS 01 ATEX 7005 |
| - | - | - | 9 | 360 | 8.7 | 352.8 | 25 | 0.05 | 4.9 | 57 | 613 | |
| - | - | - | 9 | 360 | 17.4 | 355 | 49 | 0.11 | 0.346 | 15.2 | 249 | |
| Z 764 | Z 864 | - | 12 | 1k | 11.6 | 980 | 12 | 0.03 | 1.41 | 240 | 1.0 | BAS 01 ATEX 7005 |
| - | - | - | 12 | 1k | 11.6 | 980 | 12 | 0.03 | 1.41 | 240 | 1.0 | |
| - | - | - | 12 | 1k | 11.6 | 490 | 24 | 0.06 | 1.41 | 61 | 360 | |
| - | - | Z 964 | 12 | 1k | 12 | 980 | 12 | 0.04 | 1.41 | 240 | 1.0 | BAS 01 ATEX 7005 |
| - | - | - | 12 | 1k | 12 | 980 | 12 | 0.04 | 1.41 | 240 | 1.0 | |
| - | - | - | 12 | 1k | 24 | 490 | 24 | 0.08 | 0.125 | 61 | 360 | |
| Z 765 | Z 865 | - | 15 | 100 | 14.7 | 98 | 150 | 0.55 | 0.58 | 1.3 | 64 | BAS 01 ATEX 7005 |
| - | - | - | 15 | 100 | 14.7 | 98 | 150 | 0.55 | 0.58 | 1.3 | 64 | |
| - | - | - | 15 | 100 | 14.7 | 49 | 300 | 1.1 | 0.58 | 0.32 | 22 | |
| Z 765.F | Z 865.F | - | 15 | 100 | 14.7 | 98 | 150 | 0.55 | 0.62 | 1.45 | 67 | BAS 01 ATEX 7096 |
| - | - | - | 15 | 100 | 14.7 | 98 | 150 | 0.55 | 0.62 | 1.45 | 67 | |
| - | - | - | 15 | 100 | 14.7 | 49 | 300 | 1.1 | 0.62 | 0.32 | 22 | |

Date of issue 05/13/05

Data sheet Zener barriers

| Max. end-to-end resistance Ω | U _{in} at 10 μA V | U _{in} max V | Fuse rating mA | see circuit diagram No. | Circuit diagram | | see note 2 |
|---------------------------------|-------------------------------|--------------------------|-------------------|-------------------------|----------------------------|-----------------------|------------|
| | | | | | Hazardous area connections | Safe area connections | |
| 18.18 | 0.9 (1 μA) | 4.8 | 250 | 1), 2) | | | |
| 18.18 | 0.9 (1 μA) | 4.7 | 250 | 3) | | | |
| 56 | 6.5 | 8.9 | 100 | 1), 2) | | | |
| 56 | 6.5 | 9.3 | 100 | 3) | | | |
| 29 | 13.7 | 14.6 | 160 | | | | |
| 107 | 13.0 | 13.6 | 100 | 1), 2) | | | |
| 121 | 13.0 | 13.8 | 63 | | | | |
| 107 | 13.0 | 14.0 | 100 | 3) | | | |
| 1025 | 13.0 | 13.6 | 100 | 3) | | | |
| 1025 | 13.0 | 14.0 | 100 | 1), 2) | | | |
| 166 | 19.0 | 20.1 | 50 | 1), 2) | | | |
| 327 | 26.5 | 28.0 | 50 | 1), 2) | | | |
| 250 | 26.5 | 28.0 | 80 | | | | |
| 341 | 26.5 | 28.0 | 50 | | | | |
| 273 | 26.5 | 28.0 | 50 | | | | |
| 342 + 2 V | 26.5 | 28.0 | 50 | 1), 2) | | | |
| 327 | 26.0 | 27.6 | 50 | 3) | | | |
| 18.18 | 0.9 (1 μA) | 4.8 | 250 | 4), 5) | | | |
| 18.18 | 0.9 (1 μA) | 4.8 | 250 | | | | |
| - | - | - | - | | | | |
| 18.18 | 0.9 (1 μA) | 4.7 | 250 | 6) | | | |
| 18.18 | 0.9 (1 μA) | 4.7 | 250 | | | | |
| - | - | - | - | | | | |
| - | - | - | - | | | | |
| 15.5 | 6.0 | 6.9 | 200 | 4), 5) | | | |
| 15.5 | 6.0 | 6.9 | 200 | | | | |
| - | - | - | - | | | | |
| 106 | 6.5 | 8.1 | 100 | 6) | | | |
| 106 | 6.5 | 8.1 | 100 | | | | |
| - | - | - | - | | | | |
| 113 | 6.5 | 8.0 | 100 | | | | |
| 380 | 6.5 | 8.1 | 50 | | | | |
| 380 | 6.5 | 8.1 | 50 | | | | |
| 380 | 6.5 | 8.1 | 50 | 6) | | | |
| 380 | 6.5 | 8.1 | 50 | | | | |
| - | - | - | - | | | | |
| 1033 | 10.0 | 11.0 | 50 | 4), 5) | | | |
| 1033 | 10.0 | 11.0 | 50 | | | | |
| - | - | - | - | | | | |
| - | - | - | - | | | | |
| 1033 | 10.0 | 11.7 | 50 | 6) | | | |
| 1033 | 10.0 | 11.7 | 50 | | | | |
| - | - | - | - | | | | |
| - | - | - | - | | | | |
| 107 | 13.0 | 13.6 | 100 | 4), 5) | | | |
| 107 | 13.0 | 13.6 | 100 | | | | |
| - | - | - | - | | | | |
| 121 | 13.0 | 13.9 | 63 | | | | |
| 121 | 13.0 | 13.9 | 63 | | | | |
| - | - | - | - | | | | |
| - | - | - | - | | | | |
| - | - | - | - | | | | |

Date of issue 05/13/05

Data sheet Zener barriers

| Type | | | Nominal data | | Intrinsically safe characteristics for [EEex ia] IIC | | | | | | | | Certification no. |
|-----------|-----------|---------|--------------|----------|------------------------------------------------------|------------------------|------------|---------------|----------------------|----------------|-----------|------------------|-------------------|
| + ve | - ve | a.c. | V | Ω | U_Z (V) | R_{min} (Ω) | I_K (mA) | P_{max} (W) | C_{max} (μ F) | L_{max} (mH) | L/R Ratio | | |
| - | - | Z 966 | 12 | 150 | 12 | 147 | 82 | 0.24 | 1.41 | 5.52 | 147 | BAS 01 ATEX 7005 | |
| | | | 12 | 150 | 12 | 147 | 82 | 0.24 | 1.41 | 5.52 | 147 | | |
| | | | 24 | 73.5 | 24 | 73.5 | 164 | 0.48 | 0.125 | 1.38 | 57 | | |
| - | - | Z 966.F | 12 | 150 | 12 | 147 | 82 | 0.24 | - | - | - | BAS 01 ATEX 7096 | |
| | | | 12 | 150 | 12 | 147 | 82 | 0.24 | - | - | - | | |
| | | | 24 | 73.5 | 24 | 73.5 | 164 | 0.49 | - | - | - | | |
| - | - | Z 966.H | 12 | 75 | 12 | 73.5 | 164 | 0.49 | 1.41 | 1.38 | 75 | BAS 01 ATEX 7005 | |
| | | | 12 | 75 | 12 | 73.5 | 164 | 0.49 | 1.41 | 1.38 | 75 | | |
| | | | 24 | 36.5 | 24 | 36.5 | 328 | 0.98 | 0.125 | 0.33 | 36 | | |
| Z 772 | Z 872 | - | 22 | 150 | 22 | 147 | 150 | 0.82 | 0.17 | 1.45 | 45 | BAS 01 ATEX 7005 | |
| | | | 22 | 150 | 22 | 147 | 150 | 0.82 | 0.17 | 1.45 | 45 | | |
| | | | 22 | 150 | 22 | 73.5 | 300 | 1.64 | no approval for IIC | | | | |
| Z 778 | Z 878 | - | 28 | 600 | 28 | 607 | 46 | 0.32 | 0.083 | 17.2 | 109 | BAS 01 ATEX 7005 | |
| | | | 28 | 600 | 28 | 607 | 46 | 0.32 | 0.083 | 17.2 | 109 | | |
| | | | 28 | 300.5 | 28 | 303.5 | 93 | 0.65 | 0.083 | 3.05 | 42 | | |
| Z 779 | Z 879 | - | 28 | 300 | 28 | 301 | 93 | 0.65 | 0.083 | 3.05 | 56 | BAS 01 ATEX 7005 | |
| | | | 28 | 300 | 28 | 301 | 93 | 0.65 | 0.083 | 3.05 | 56 | | |
| | | | 28 | 300 | 28 | 150.5 | 186 | 1.3 | no approval for IIC | | | | |
| Z 779.H | Z 879.H | - | 28 | 240 | 28 | 235 | 119 | 0.83 | 0.083 | 1.82 | 44 | BAS 01 ATEX 7005 | |
| | | | 28 | 240 | 28 | 235 | 119 | 0.83 | 0.083 | 1.82 | 44 | | |
| | | | 28 | 117.5 | 28 | 117.5 | 238 | 1.67 | no approval for IIC | | | | |
| Z 779.F | Z 879.F | - | 28 | 300 | 28 | 301 | 93 | 0.65 | 0.083 | 4.21 | 55 | BAS 00 ATEX 7096 | |
| | | | 28 | 300 | 28 | 301 | 93 | 0.65 | 0.083 | 4.21 | 55 | | |
| Z 779.H.F | Z 879.H.F | - | 28 | 240 | 28 | 235 | 120 | 0.83 | 0.083 | 2.59 | 44 | BAS 01 ATEX 7096 | |
| | | | 28 | 240 | 28 | 235 | 120 | 0.83 | 0.083 | 2.59 | 44 | | |
| Z 786 | Z 886 | - | 28 | Diode | 28 | Diode | 0 | 0.0 | 0.083 | - | - | BAS 01 ATEX 7005 | |
| | | | 28 | Diode | 28 | Diode | 0 | 0.0 | 0.083 | - | - | | |
| | | | 28 | Diode | 28 | Diode | 0 | 0.0 | 0.083 | - | - | | |
| Z 787 | Z 887 | - | 28 | 300 | 28 | 301 | 93 | 0.65 | 0.083 | 3.05 | 56 | BAS 01 ATEX 7005 | |
| | | | 28 | Diode | 28 | Diode | 0 | 0.083 | - | - | - | | |
| | | | 28 | 301 | 28 | 301 | 93 | 0.65 | 0.083 | 3.05 | 56 | | |
| Z 787.H | Z 887.H | - | 28 | 240 | 28 | 235 | 119 | 0.83 | 0.083 | 2.82 | 44 | BAS 01 ATEX 7005 | |
| | | | 28 | Diode | 28 | Diode | 0 | 0.083 | see note 1 | | | | |
| | | | 28 | 235 | 28 | 235 | 119 | 0.83 | 0.083 | 2.82 | 44 | | |
| Z 787.F | Z 887.F | - | 28 | 300 | 28 | 301 | 93 | 0.65 | 0.083 | 4.21 | 55 | BAS 01 ATEX 7096 | |
| | | | 28 | Diode | 28 | Diode | 0 | 0.083 | - | - | - | | |
| | | | 28 | 301 | 28 | 301 | 93 | 0.65 | 0.083 | 4.21 | 55 | | |
| Z 787.H.F | Z 887.H.F | - | 28 | 240 | 28 | 235.2 | 120 | 0.83 | 0.083 | 2.59 | 44 | BAS 01 ATEX 7096 | |
| | | | 28 | Diode | 28 | Diode | 0 | 0.083 | - | - | - | | |
| | | | 28 | 240 | 28 | 235.2 | 120 | 0.83 | 0.083 | 2.59 | 44 | | |
| Z 788 | Z 888 | - | 28 | 300 | 28 | 301 | 93 | 0.65 | 0.083 | 3.05 | 56 | BAS 01 ATEX 7005 | |
| | | | 10 | 50 | 28 | 9.56 | 49 | 195 | 0.47 | 3.0 | 0.86 | 73 | |
| | | | 28 | 42 | 28 | 42 | 288 | 0.87 | 0.083 | 0.32 | 26 | | |
| Z 788.H | Z 888.H | - | 28 | 240 | 28 | 235 | 119 | 0.83 | 0.083 | 1.82 | 44 | BAS 01 ATEX 7005 | |
| | | | 10 | 50 | 28 | 9.56 | 49 | 195 | 0.47 | 3.0 | 0.86 | 73 | |
| | | | 28 | 40 | 28 | 40 | 314 | 1.0 | 0.083 | 0.26 | 25 | | |
| Z 788.R | - | - | 28 | 300 | 28 | 301 | 93 | 0.65 | 0.083 | 3.05 | 56 | BAS 01 ATEX 7005 | |
| | | | 10 | 50 | 28 | 9.56 | 49 | 195 | 0.47 | 3.0 | 0.86 | 73 | |
| | | | 28 | 42 | 28 | 42 | 288 | 0.87 | 0.083 | 0.32 | 26 | | |
| Z 789 | - | - | 28 | 300 | 28 | 307 | 91.2 | 0.638 | - | - | - | BAS 01 ATEX 7005 | |
| | | | 28 | Diode | 28 | - | - | - | - | - | - | | |
| | | | 28 | Diode | 28 | - | - | - | - | - | - | | |
| Z 796 | Z 896 | - | 26.6 | 320 | 26.6 | 314 | 85 | 0.56 | 0.094 | 5.14 | 64 | BAS 01 ATEX 7005 | |
| | | | 20.5 | 415 | 20.5 | 407 | 50 | 0.26 | 0.204 | 14.6 | 138 | | |
| | | | 26.6 | 177 | 26.6 | 177 | 135 | 0.82 | 0.094 | 2.05 | 34 | | |

05/13/05
Date of issue

Data sheet Zener barriers

| Max. end-to-end resistance | U_{in} at 10 μ A | U_{in} max | Fuse rating | see circuit diagram No. | Circuit diagram | see note 2 |
|----------------------------|------------------------|--------------|-------------|-------------------------|----------------------------|-----------------------|
| Ω | V | V | mA | | Hazardous area connections | Safe area connections |
| 166 | 10.0 | 11.7 | 50 | 6) | | A1 A2 B |
| 166 | 10.0 | 11.7 | 50 | | | |
| - | - | - | - | | | |
| 169 | 10.0 | 11.9 | 63 | 6) | | A1 A2 B |
| 169 | 10.0 | 11.9 | 63 | | | |
| - | - | - | - | | | |
| 82 | 10.0 | 11.7 | 100 | 6) | | A1 A2 B |
| 82 | 10.0 | 11.7 | 100 | | | |
| - | - | - | - | | | |
| 166 | 19.0 | 20.1 | 50 | 4), 5) | | A1 A2 B |
| 166 | 19.0 | 20.1 | 50 | | | |
| - | - | - | - | | | |
| 646 | 26.5 | 28.0 | 50 | 4), 5) | | A1 A2 B |
| 646 | 26.5 | 28.0 | 50 | | | |
| - | - | - | - | | | |
| 327 | 26.5 | 28.0 | 50 | 4), 5) | | A1 A2 B |
| 327 | 26.5 | 28.0 | 50 | | | |
| - | - | - | - | | | |
| 250 | 26.5 | 28.0 | 80 | 4), 5) | | A1 A2 B |
| 250 | 26.5 | 28.0 | 80 | | | |
| - | - | - | - | | | |
| 341 | 26.5 | 28.0 | 50 | 4), 5) | | A1 A2 B |
| 341 | 26.6 | 28.0 | 50 | | | |
| 273 | 26.5 | 28.0 | 50 | | | |
| 273 | 26.5 | 28.0 | 50 | | | |
| 36 + 0.9 V | 26.5 | 28.0 | 50 | 8) | | A1 A2 B |
| 36 + 0.9 V | 26.5 | 28.0 | 50 | | | |
| - | - | - | - | | | |
| 327 | 26.5 | 28.0 | 50 | 9) | | A1 A2 B |
| 36 + 0.9 V | 26.5 | 28.0 | 50 | | | |
| - | - | - | - | | | |
| 250 | 26.5 | 28.0 | 80 | 9) | | A1 A2 B |
| 25 + 0.9 V | 26.5 | 28.0 | 80 | | | |
| - | - | - | - | | | |
| 341 | 26.5 | 28.0 | 50 | 9) | | A1 A2 B |
| 50 + 0.9 V | 26.5 | 28.0 | 50 | | | |
| - | - | - | - | | | |
| 273 | 26.5 | 28.0 | 50 | 9) | | A1 A2 B |
| 43 + 0.9 V | 26.5 | 28.0 | 50 | | | |
| - | - | - | - | | | |
| 327 | 26.5 | 28.0 | 50 | 4), 5) | | A1 A2 B |
| 64 | 6.5 | 9.1 | 50 | | | |
| - | - | - | - | | | |
| 250 | 26.5 | 28.0 | 80 | 4), 5) | | A1 A2 B |
| 64 | 6.5 | 9.1 | 80 | | | |
| - | - | - | - | | | |
| 327 | 26.5 | 28.0 | 50 | 7) | | A1 A2 B |
| 64 | - | 9.1 | 50 | | | |
| - | - | - | - | | | |
| 640 | 26.5 | 27.5 | 50 | ???) | | A1 A2 B |
| 36 + 0.9 V | 26.5 | 27.5 | 50 | | | |
| 36 + 0.9 V | 26.5 | 27.5 | 50 | | | |
| 340 | 24.0 | 25.1 | 50 | 4), 5) | | A1 A2 B |
| 437 | 18.0 | 19.5 | 50 | | | |
| - | - | - | - | | | |

05/13/05
Date of issue

Data sheet Zener barriers

| Type | | | Nominal data | | Intrinsically safe characteristics for [EEEx ia] IIC | | | | | | | Certification no. | | |
|----------------|------|-------|--------------|---------|------------------------------------------------------|----------------------|---------------------|----------------------|-----------------------|-----------------------|-----------|-------------------|----|------------------|
| + ve | - ve | a.c. | V | Ω | U _Z (V) | R _{min} (Ω) | I _k (mA) | P _{max} (W) | C _{max} (μF) | L _{max} (mH) | L/R Ratio | | | |
| - | - | Z 960 | 10 | 50 | 9.94 | 49 | 203 | 0.50 | 3,0 | 0.86 | 73 | BAS 01 ATEX 7005 | | |
| | | | 10 | 50 | 9.94 | 49 | 203 | 0.50 | 3,0 | 0.86 | 73 | | | |
| | | | 10 | 50 | 9.94 | 24.5 | 406 | 1.0 | 3,0 | 0.19 | 26 | | | |
| | | - | - | Z 960.F | 10 | 50 | 9.94 | 98 | 203 | 0.51 | 2.63 | 0.82 | 69 | BAS 01 ATEX 7096 |
| | | | | | 10 | 50 | 9.94 | 49 | 203 | 0.51 | 2.63 | 0.82 | 69 | |
| | | | | | 10 | 50 | 9.94 | 49 | 406 | 1.02 | 2.63 | 0.82 | 25 | |
| - | - | Z 965 | 15 | 100 | 15 | 98 | 153 | 0.57 | 0.58 | 1.3 | 64 | BAS 01 ATEX 7005 | | |
| | | | 15 | 100 | 15 | 98 | 153 | 0.57 | 0.58 | 1.3 | 64 | | | |
| | | | 15 | 100 | 15 | 49 | 306 | 1.14 | 0.58 | 0.29 | 20 | | | |
| - | - | Z 967 | 17 | 120 | 16.8 | 117 | 143 | 0.60 | 0.38 | 1.63 | 60 | BAS 01 ATEX 7005 | | |
| | | | 17 | 120 | 16.8 | 117 | 143 | 0.60 | 0.38 | 1.63 | 60 | | | |
| | | | 17 | 120 | 16.8 | 58 | 286 | 1.20 | 0.38 | 0.24 | 21 | | | |
| - | - | Z 972 | 22 | 300 | 22 | 301 | 73 | 0.40 | 0.17 | 6.95 | 90 | BAS 01 ATEX 7005 | | |
| | | | 22 | 300 | 22 | 301 | 73 | 0.40 | 0.17 | 6.95 | 90 | | | |
| | | | 22 | 300 | 22 | 150 | 146 | 0.80 | 0.17 | 1.45 | 35 | | | |
| - | - | Z 978 | 28 | 600 | 28 | 607 | 46 | 0.32 | 0.083 | 17.2 | 109 | BAS 01 ATEX 7005 | | |
| | | | 28 | 600 | 28 | 607 | 46 | 0.32 | 0.083 | 17.2 | 109 | | | |
| | | | 28 | 600 | 28 | 304 | 93 | 0.65 | 0.083 | 3.05 | 42 | | | |
| - | - | Z 954 | 4.5 | 12 | 4.5 | 11.76 | 383 | 0.43 | 100 | 0.24 | 81 | BAS 01 ATEX 7005 | | |
| | | | 4.5 | 12 | 4.5 | 11.76 | 383 | 0.43 | 100 | 0.24 | 81 | | | |
| | | | 4.5 | 12 | 4.5 | 11.76 | 383 | 0.43 | 100 | 0.24 | 81 | | | |
| | | | 9.0 | | 9.0 | 5.88 | 765 | 0.86 | 4.9 | 0.068 | 41 | | | |
| | | | 9.0 | | 9.0 | 3.92 | 1150 | 1.29 | 4.9 | 0.03 | 27 | | | |
| | | | 9.0 | | 9.0 | 17.64 | 510 | 1.15 | 4.9 | 0.12 | 30 | | | |
| Dummy Z 799 | | | | | | | | | | | | | | |

Date of issue 05/13/05

Data sheet Zener barriers

| Max. end-to-end resistance | U _{in} at 10 μA | U _{in} max | Fuse rating | see circuit diagram No. | Circuit diagram Hazardous area connections | Safe area connections | see note 2 |
|----------------------------|--------------------------|---------------------|-------------|-------------------------|-----------------------------------------------|-------------------------------|-------------------------------|
| Ω | V | V | mA | | | | |
| 64 | 6.5 | 9.5 | 50 | 10) | | A1 A2 B | A1 A2 B |
| 64 | 6.5 | 9.5 | 50 | | | | |
| - | - | - | - | | | | |
| - | - | - | - | | | | |
| 79 | 6.5 | 9.7 | 50 | | | | |
| 79 | 6.5 | 9.7 | 50 | | | | |
| 115 | 13.0 | 14.2 | 50 | 10) | | A1 A2 B | A1 A2 B |
| 115 | 13.0 | 14.2 | 50 | | | | |
| - | - | - | - | | | | |
| 136 | 15.0 | 16.2 | 50 | 10) | | A1 A2 B | A1 A2 B |
| 136 | 15.0 | 16.2 | 50 | | | | |
| - | - | - | - | | | | |
| 327 | 19.0 | 20.9 | 50 | 10) | | A1 A2 B | A1 A2 B |
| 327 | 19.0 | 20.9 | 50 | | | | |
| - | - | - | - | | | | |
| 646 | 26.0 | 27.6 | 50 | 10) | | A1 A2 B | A1 A2 B |
| 646 | 26.0 | 27.6 | 50 | | | | |
| - | - | - | - | | | | |
| 27.27 | 0.9 (1 μA) | 4.9 | 50 | 11) | | A1 A2 A3 B B C | A1 A2 A3 B B C |
| 27.27 | 0.9 (1 μA) | 4.9 | 50 | | | | |
| 27.27 | 0.9 (1 μA) | 4.9 | 50 | | | | |
| - | - | - | - | | | | |
| - | - | - | - | | | | |
| - | - | - | - | | | | |
| | | | | | | | |

Note 1:

Zener barriers type Z 787H and Z 887H have channels with diode returns.

The intrinsically safe terminals for the channels with diode returns should be regarded as 28 V voltage sources.

The 28 V must be considered as the theoretical maximum up to which a capacitive load can be applied to the intrinsically safe terminals due to the leakage current of the diode return. This voltage is only used in calculating the load capacitance.

Note 2:

A1, A2 and A3 are separate channels.

B: Two channels in parallel circuit with a ground connection.

C: Two channels in series circuit without a ground return.

Date of issue 05/13/05

0.1 Application examples

Temperature measurement

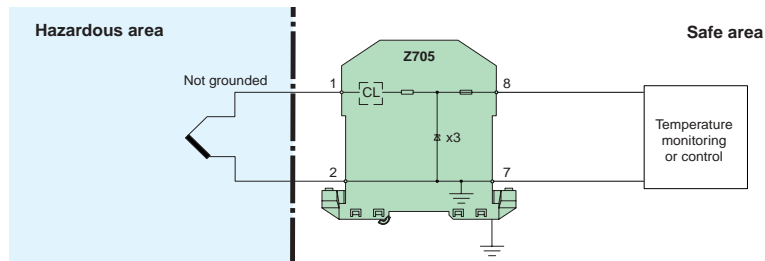

The simplest and most favourably priced solution is a single-channel Zener barrier. It should be noted, however, that the device is not grounded in the safe area. The system is approved for [EEx ia] IIC.

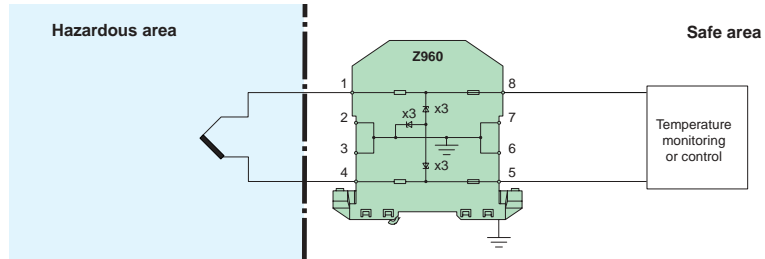

The use of a two-channel barrier prevents the direct ground connection of the intrinsically safe circuit. Grounding only takes place in the event of a fault, when the Zener diodes conduct. This circuit arrangement prevents the occurrence of mutual interference between the various circuits. The system is approved for [EEx ia] IIC.

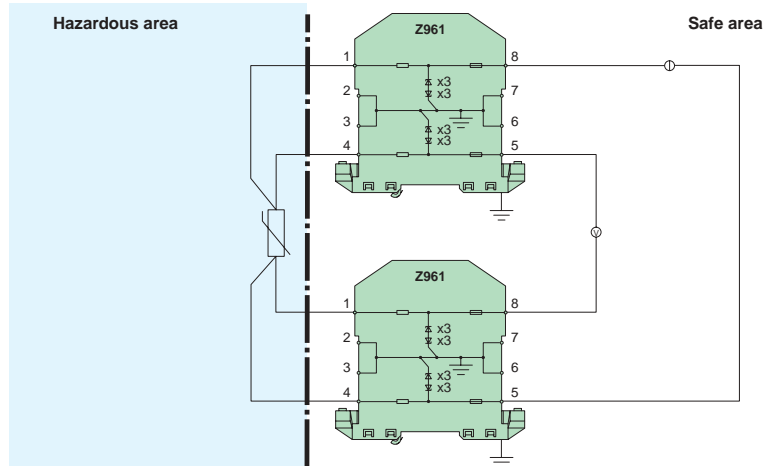

The illustration shows the set up for a temperature measurement with a 4-wire Pt100. None of the 4 wires is connected directly to ground. The complete system is therefore "quasi ground-free". This is the best option when the intention is to suppress the influence of the end-to-end resistance of the barrier on the measuring accuracy as far as possible.

Date of issue 05/13/05

Temperature measurement

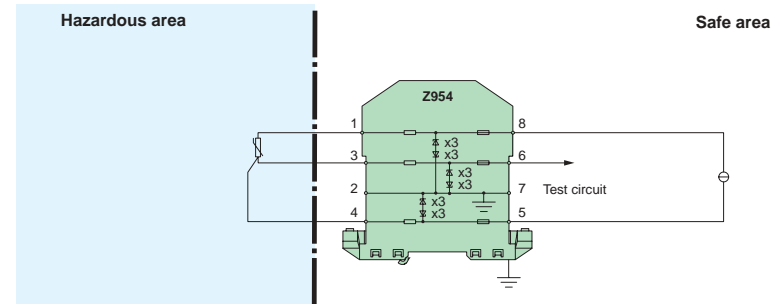

The circuit arrangement shows the connection of a Pt100 in 3-wire technology, using the 3-channel Zener barrier Z 954. The whole system is quasi ground-free. All 3 barriers have identical end-to-end resistances, so that the resulting error is restricted to a minimum. The system is approved for [EEx ia] IIC.

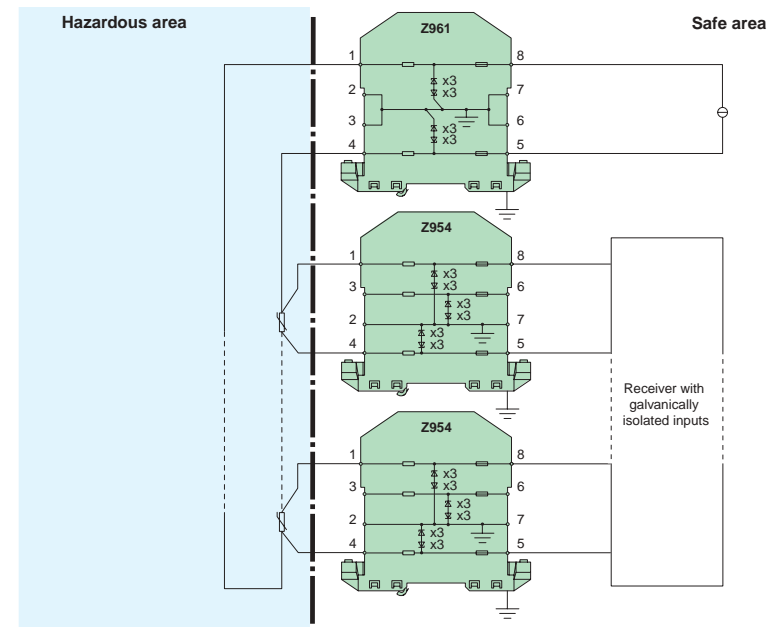

The circuit consists of a system of a maximum of seven Pt100s. The Pt100s are connected in series to a constant current source. Each voltage signal is transferred to a receiver via a Z 954. The Z 954s have been selected due to their high end-to-end resistance. Due to the high input resistance of the receiver, the high end-to-end resistance has practically no effect on the accuracy of measurement.

Date of issue 05/13/05

Data sheet Zener barriers

0 mA ... 20 mA/4 mA ... 20 mA transmitter

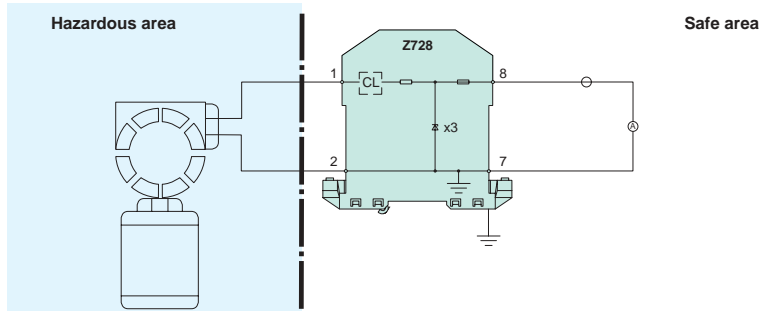

If a ground-free power supply is available, the use of a single-channel Zener barrier, grounded in the safe area, represents the simplest and most economical solution. The ammeter can be used in combination with a recording instrument, a trip amplifier, or a 250 Ω resistance, or replaced by these devices. In so doing, the overall resistance of the arrangement must be taken into account. The working range of the barrier caters for

an input voltage of up to 27 V. For each built-in 250 Ω resistance the output voltage of the power supply can be increased by 1 V. By using a 250 Ω resistance and a supply voltage of 28 V, a source of 16.5 V at 20 mA is available to the transmitter in the hazardous area. The internal voltage drop across the barrier is then 6.5 V. The system is approved for [EEx ia] IIC.

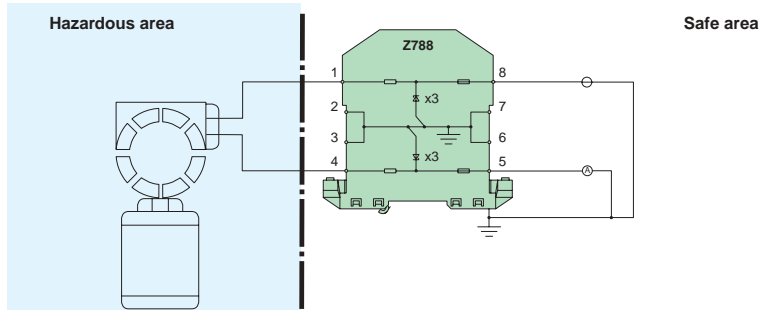

With this 2-channel Zener barrier, it is possible to supply a number of circuits with one source. All the wiring is quasi ground-free. The maximum voltage supply is 27 V. The internal voltage drop across the barrier is 7.8 V at 20 mA, so that 19.2 V are available for the field device and ammeter. If the

ammeter for converting the current signal into a 1 V ... 5 V voltage signal is replaced by a 250 Ω resistance, then 14.2 V are available at the field device. The system is approved for [EEx ia] IIC.

Date of issue 05/13/05

Data sheet Zener barriers

0 mA ... 20 mA/4 mA ... 20 mA transmitter

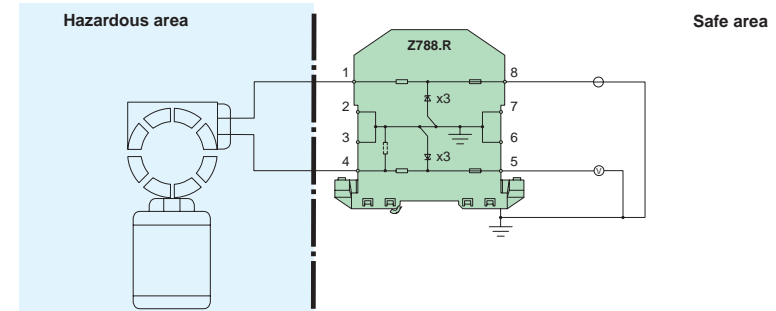

This system can be used if the field device requires a relatively high voltage. A 250 Ω resistance is connected in parallel with the intrinsically safe output of the 10 V/50 Ω output of this 2-

channel barrier. Thus a voltage of 15.5 V is available at the field device if the voltage supply is 27 V. The system is approved for [EEx ia] IIC.

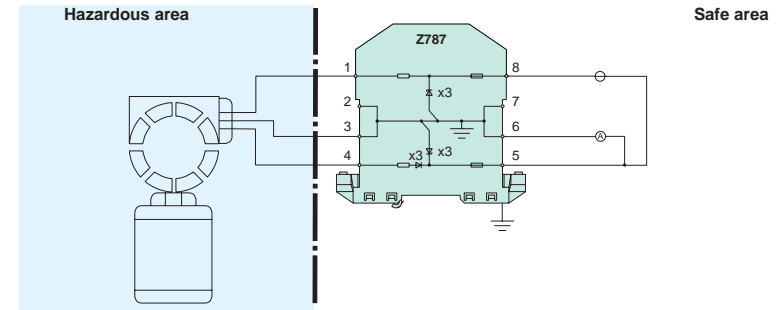

The combination of a 28 V, 300 Ω and a 28 V barrier with diode return is the solution for applications with 3-wire transmitters. Special attention must be paid here to the internal voltage

drop. The reason for this is the diode return. The system is approved for [EEx ia] IIC.

Date of issue 05/13/05

SMART transmitter

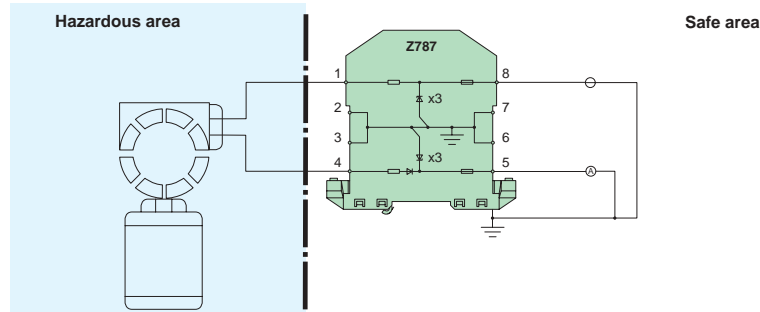

The simplest possible solution is the use of a 2-channel Zener barrier with 28 V, 300 Ω and 28 V diode return. If a regulated power supply unit provides an output voltage of 27 V, 13.9 V will be available to the transmitter and wiring in the hazardous area.

The data transfer is bidirectional, so that a non-certificated communicator can be connected and used in the safe area. The system is approved for [EEx ia] IIC.

Strain gauge bridges

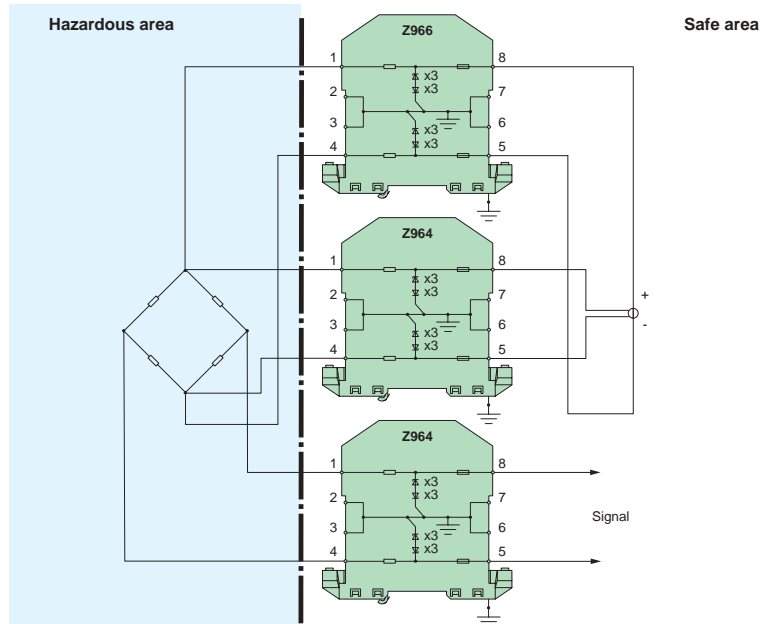

The strain gauge bridge is supplied via the Z 966. The Z 966 enables a 350 Ω strain gauge bridge to be supplied with 8 V. The voltage feedback via the Z 964 can be dispensed with, although in practice most applications require this feedback to

obtain the best possible accuracy of measurement. The millivolt signal is transferred to the safe area via the Z 964. The system is approved for [EEx ia] IIC.

Date of issue 05/13/05

Wire strain gauges

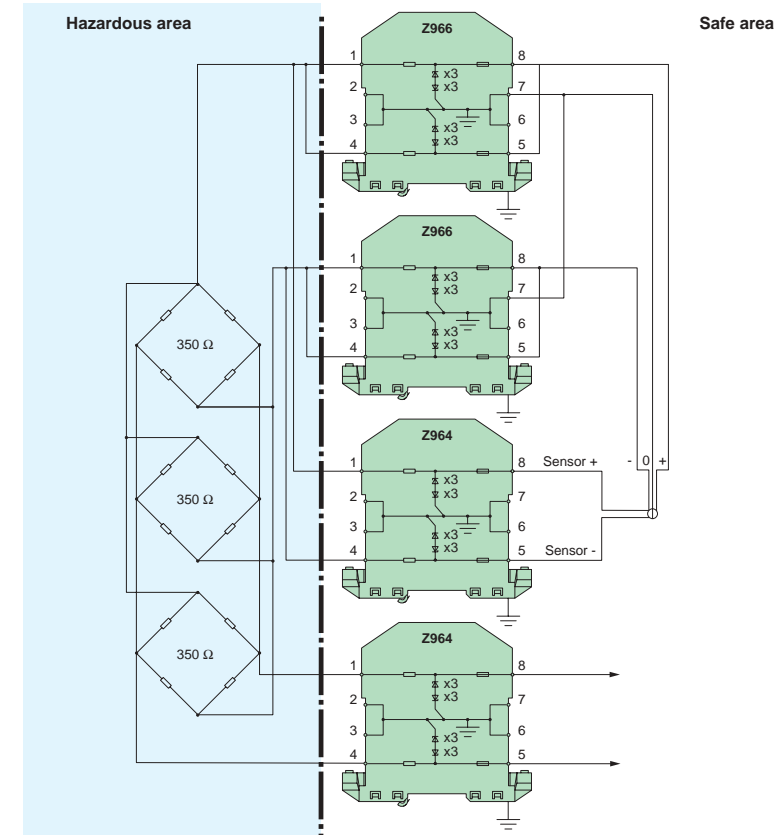

If more than one strain gauge bridge is to be supplied from a common power supply (in the example shown above there are three), a possible solution is to supply them via two Z 966s, as shown.

Both channels of these Zener barriers are arranged in parallel in order to reduce the end-to-end resistance. This arrangement provides 8 V to the bridges if the voltage supply is 20 V. The system is approved for [EEx ib].

Date of issue 05/13/05

Data sheet Zener barriers

Potentiometric position detection

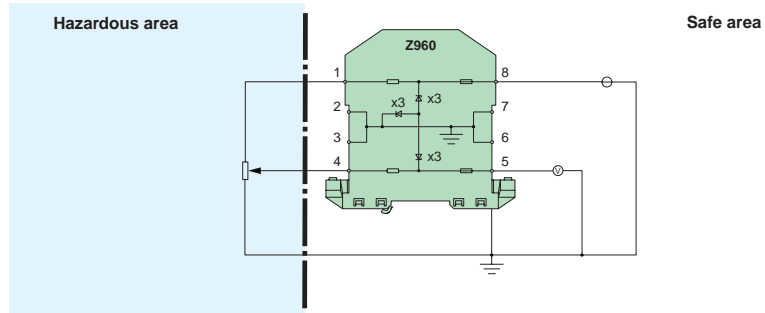

Applications in which the accuracy is not critical can be satisfied as shown above. The intrinsically safe circuit has a direct connection to ground. An additional resistance on this

side would have an effect on the voltage signal and would have to be taken into account. The system is approved for [EEx ia] IIC.

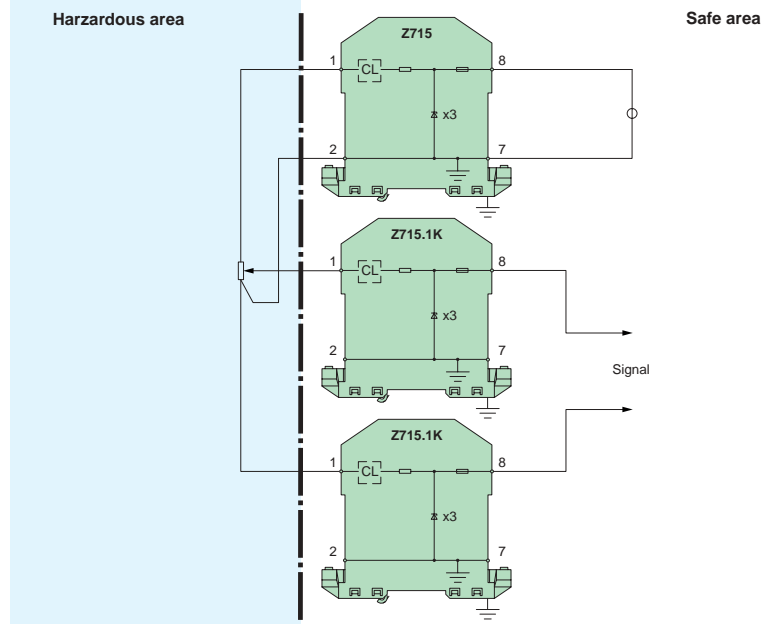

If greater accuracy is required, a 4-wire solution must be applied. The Z 715 Zener barrier transfers the power supply to the potentiometer, whilst two Z 715.1K barriers transfer the

signal to the receiver. The supply voltage in the example above could be 13 V.

Date of issue 05/13/05

Data sheet Zener barriers

Solenoid valves

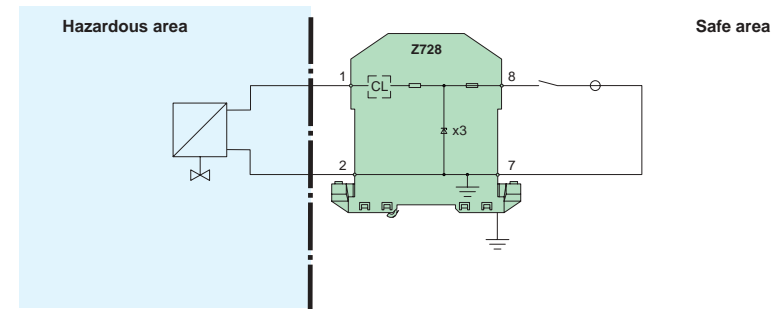

The simplest and most economical solution is a single channel Zener barrier, with the power supply grounded on its safe side. If the valve requires 30 mA at a minimum 12 V, then at a

supply voltage of 27 V, 4 V would remain for the voltage drop through the field wiring. The system is approved for [EEx ia] IIC.

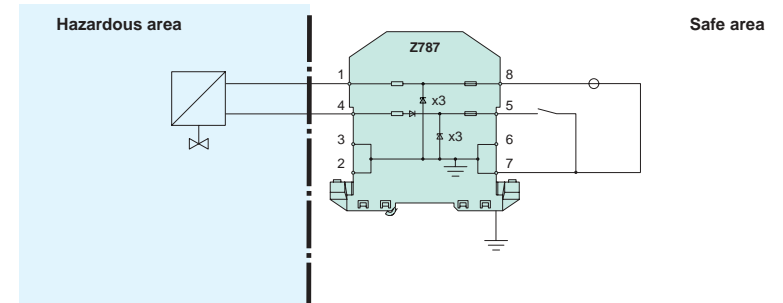

If the switch is in parallel circuit with the nominal mains voltage, it is usual to use a barrier combination of 28 V, 300 Ω and a 28 V diode return. In this solution, special attention has to be

paid to the voltage drop in the barrier, since the diode return causes an additional loss of voltage. The system is approved for [EEx ia] IIC.

Date of issue 05/13/05

Switch status

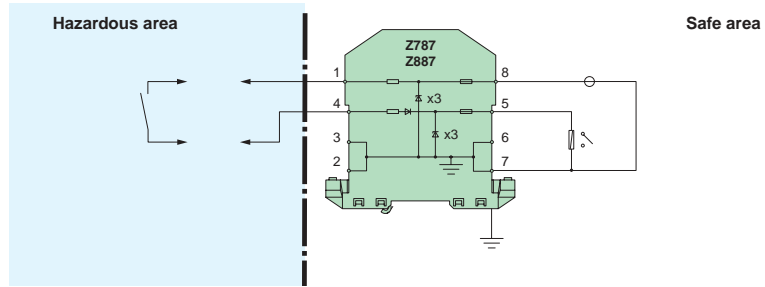

In the traditional method of switch status detection, the switch is provided with noble metal contacts suitable for low voltages and currents. A ground fault in any field wire leaves the relay in the de-energised state, despite the switch being closed. This problem is solved by the use of quasi ground-free wiring.

At a nominal voltage of up to 27 V, a typical coil with 12 V and approx. 350 Ω can be used to match the power. The Zener barrier is approved for [EEEx ia] IIC. Negative polarities can be accommodated with the Z 887.

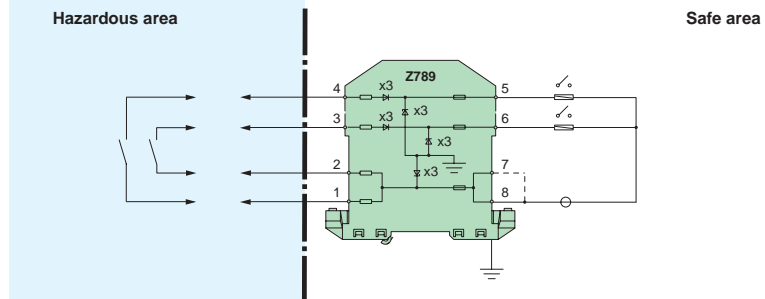

Pulse transmission and flow measurement

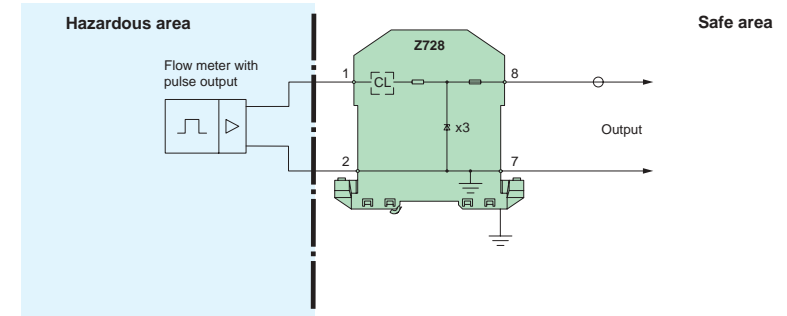

The simplest method of flow measurement, with or without a pre-amplifier, is illustrated in the circuit above. The flow meter sensor generates voltage or current pulses, which are transmitted to the safe area via the Z 728. If the sensor

generates sinusoidal signals, e.g. an inductive sensor, a Zener barrier for alternating polarities can be used, for example the Z 928. The Zener barrier is approved for [EEEx ia] IIC.

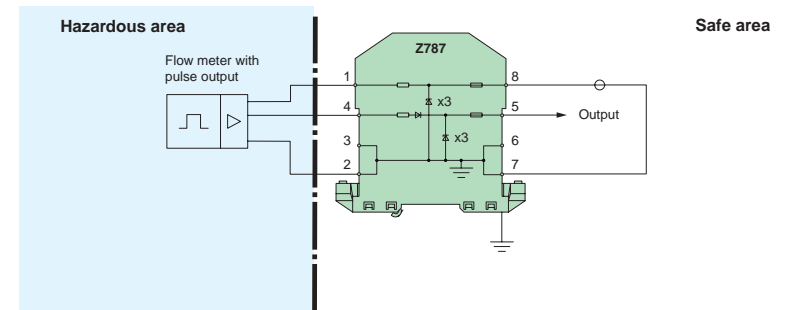

If the power supply to the flow meter is provided via a 28 V, 300 Ω barrier and ground, the signal can be transferred via the diode return of the Z 787. When selecting the receiver

(counter), consideration must be given to the fact that the high signal is damped by the diode. The system is approved for [EEEx ia] IIC.

LED display

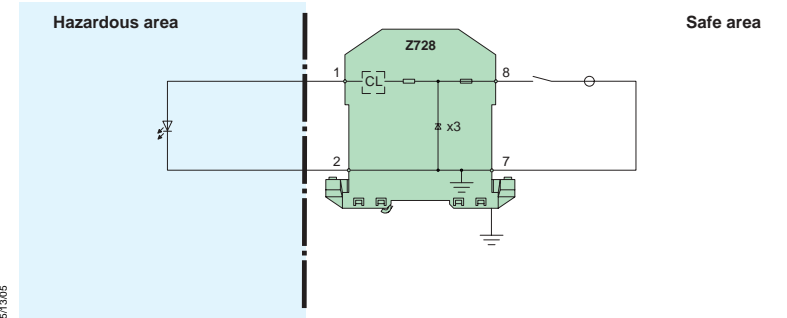

The simplest and most economical solution is the single-channel Zener barrier shown above. The nominal supply voltage is sufficiently low that the end-to-end resistance of the

barrier limits the flow of current through the LED to an acceptable value. Otherwise a current-limiting resistor is required. The system is approved for [EEEx ia] IIC.

Date of issue 05/13/05

Date of issue 05/13/05

LED display

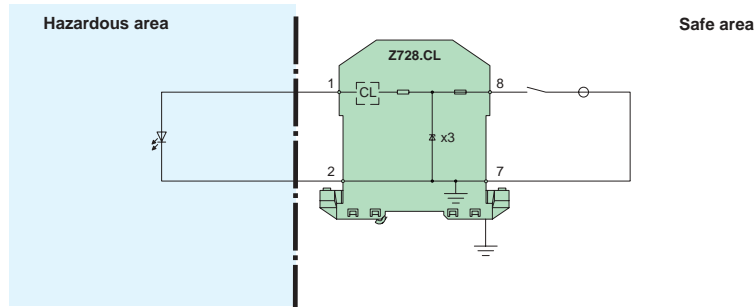

The circuit shown above does not require a current limiting resistor, since the Z 728.CL limits the current electronically to a maximum of 40 mA. At a supply voltage of 18 V ... 27 V a current of 40 mA flows in the intrinsically safe circuit. This

current reduces at lower nominal supply voltages. To special order, the Z 728.CL can be supplied with lower current-limiting values. The system is approved for [EEx ia] IIC. The Z 828.CL is also suitable for negative polarities.

Smoke and fire alarms

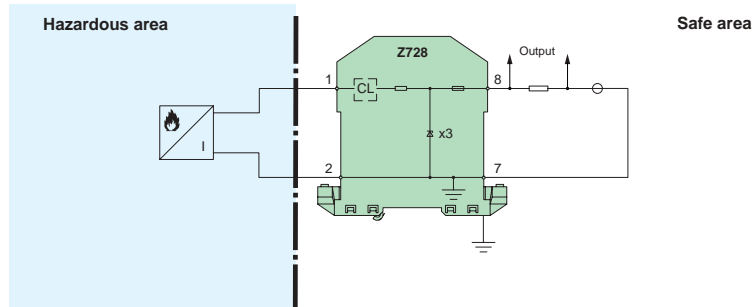

The simplest and most cost-effective solution is shown in the illustration above. With a 24 V nominal supply voltage, there is an off-state current of approx. 4 mA. When the detector responds, the current increases to approx. 25 mA or greater.

The current applied to the detector is sufficient to operate the LED display with sufficient brightness. The system is approved for [EEx ia] IIC.

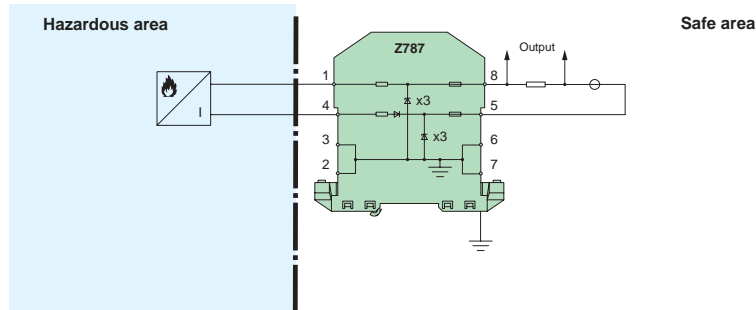

The system shown above is comparable to the Z 728 and is also relatively inexpensive. The Z 787 is a 2-channel device. In

this application the intrinsically safe circuit is quasi ground-free. The system is approved for [EEx ia] IIC.

Date of issue 05/13/05

Audible alarms

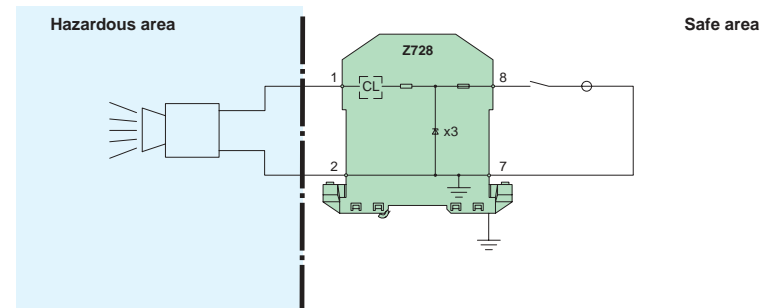

Audible alarms operate at relatively high voltages and low currents. They are approved for use with various Zener

barriers. The simplest solution is the circuit shown above.

I/P converters

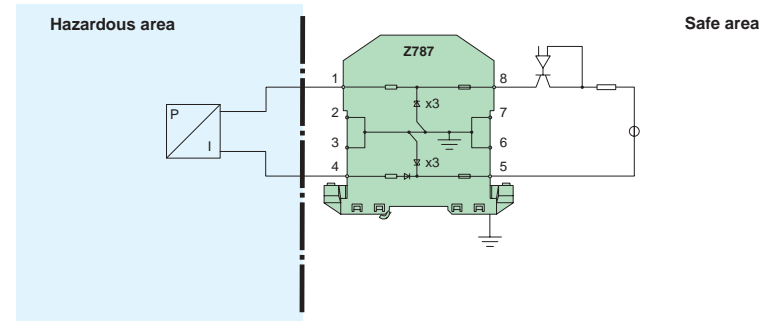

The simplest and most cost-effective solution is a single-channel Zener barrier. The nominal supply control voltage must either be ground-free or connected to the negative output to earth. In theory, the field circuit can have a resistance of

900 Ω if the voltage supply is 27 V. In practice, however, the voltage values are lower, so that the field circuit normally has a resistance of 300 Ω.

Date of issue 05/13/05